

# OPERATING MANUAL

ConCorde trailed sprayer



**Danfoil<sup>®</sup>**

## Contents

<b>1</b>	<b>Congratulations with your new danfoil field sprayer .....</b>	<b>6</b>
<b>2</b>	<b>EF declaration of conformity .....</b>	<b>7</b>
<b>3</b>	<b>Machine data.....</b>	<b>8</b>
3.1	Machine Data of your new danfoil Sprayer.....	8
3.2	Safety notes and warning signs.....	9
3.3	Information plate .....	11
3.4	Transport on public road.....	11
3.5	Lifting points.....	11
<b>4</b>	<b>Connection procedures .....</b>	<b>13</b>
4.1	Connecting the power and control computer in the tractor .....	13
4.2	Connection of Load Sensing (LS) .....	13
4.3	Hydraulic hoses and couplings on sprayer .....	14
4.4	Connecting hydraulic brake.....	15
4.5	Connecting hydraulic stand.....	15
4.6	Connecting to tractor .....	15
<b>5</b>	<b>Application of the sprayer .....</b>	<b>18</b>
5.1	Danfoil spray technology.....	18
5.1.1	Innovation – still.....	18
5.1.2	Drift reduction approval .....	18
5.1.3	Danfoil sprayer operation .....	18
5.1.4	Deposit of liquid at top and bottom .....	19
5.1.5	Greater timeliness and more spray hours .....	19
5.1.6	Reduce consumption of chemicals .....	19
<b>6</b>	<b>Operation of the sprayer's functions .....</b>	<b>20</b>
6.1	Filling with water.....	20
6.2	Chemical filler.....	20
6.3	Washing after use.....	21
<b>7</b>	<b>Description of danfoil sprayers elements .....</b>	<b>22</b>
7.1	Hydra Pro hydraulic system.....	22
7.1.1	Couplings to connecting with tractor .....	22
7.1.2	Oil filter .....	22
7.1.3	LS controlled PVG valve .....	23

7.1.4	LS controlled Rexroth valve .....	23
7.1.5	Fan motor.....	23
7.1.6	Hydraulic cylinder .....	24
7.1.7	Oil motor .....	24
7.1.8	Hydraulic stand .....	25
7.1.9	Hydraulic bake .....	25
7.1.10	Air suspension on wheel axle .....	26
7.2	Liquid system.....	26
7.2.1	Suction side canbus valve .....	27
7.2.2	Suction filter .....	27
7.2.3	Liquid pump .....	28
7.2.4	Safety valve .....	29
7.2.5	Relief valve .....	29
7.2.6	Pressure side canbus valve .....	30
7.2.7	Motor valve.....	30
7.2.8	Pressure filter .....	31
7.2.9	One-way valve.....	31
7.2.10	Flowmeter.....	32
7.2.11	Section valves .....	32
7.3	Clean water pump .....	32
7.4	Liquid Tanks.....	34
7.4.1	Sprayer tank 3000 liter.....	34
7.4.2	Clean water tank .....	34
7.4.3	Hand wash tank.....	35
7.5	Control electronics .....	35
7.5.1	Installation box.....	36
7.5.2	Installation in the tractor .....	36
7.5.3	Master control box.....	37
7.5.4	Slave control box.....	37
7.5.5	Canbus valves.....	37
<b>8</b>	<b>Boom suspension and boom construction .....</b>	<b>38</b>
8.1	Air distributor .....	39
8.2	Safety bolts.....	39
8.3	Eurofoil atomizer and anti-drip .....	39
8.3.1	Eurofoil atomizer construction .....	40
<b>9</b>	<b>Options .....</b>	<b>41</b>

9.1	End nozzles .....	41
9.2	Boom control.....	41
9.3	Line filters .....	42
9.4	Exterior washing equipment .....	42
9.5	High pressure cleaner.....	43
9.6	TrackControl – steerable tow .....	43
9.7	Work lights .....	44
9.8	Chemistry cabinet.....	44
9.9	Electronic windspeed sensor.....	44
9.10	Camera .....	45
9.11	Underbody protection shield .....	45
9.12	Autofill equipment .....	45
9.13	Ball hitch.....	45
9.14	Individual boom lift .....	46
9.15	Comfort display .....	46
9.16	Air brake system.....	46
9.17	Extra installation kit.....	47
9.18	Wheelspeed sensor .....	47
9.19	Comfort joystick .....	47
9.20	Large DSC-screen.....	48
9.21	Section control GPS.....	48
9.22	Mechanical deviation joint.....	48
<b>10</b>	<b>Preparation and maintenance of the sprayer .....</b>	<b>49</b>
10.1	Preparation and inspection of the sprayer .....	49
10.2	Before spraying .....	49
10.2.1	General inspection of the sprayer .....	49
10.2.2	Filling with water .....	50
10.2.3	Inspection of functions for spraying liquids .....	50
10.2.4	Calibration of flow gauge (liquid gauge).....	51
10.2.5	Test run in the field.....	51
10.2.6	Choice of working width.....	51
10.2.7	Adjusting the sprayer boom .....	51
10.2.8	Adjusting the boom to transport position.....	52
<b>11</b>	<b>Lubrication and maintenance scheme:.....</b>	<b>54</b>
11.1	Lubrication.....	55

11.1.1	In the front.....	55
11.1.2	In the rear .....	55
11.1.3	On the boom.....	58
<b>12</b>	<b>Dosage and filling of plant protection products.....</b>	<b>59</b>
12.1	Dosage recommendations .....	59
12.2	Filling of plant protection products.....	61
12.3	Precautions.....	62
<b>13</b>	<b>Spraying in the field .....</b>	<b>63</b>
13.1	In general.....	63
13.2	Setting of air pressure .....	63
13.2.1	General notes for air pressure.....	63
13.2.2	On bare soil and low crops (stage 1-5):.....	63
13.2.3	Beets .....	63
13.2.4	Grain .....	63
13.2.5	Potatos.....	64
13.2.6	Recommended air pressure .....	64
13.3	Adjustment of boom height .....	64
13.3.1	Recommended boom height .....	64
13.3.2	Driving in head- and tailwind.....	65
13.4	Recommended driving speed.....	65
<b>14</b>	<b>Cleaning the sprayer .....</b>	<b>66</b>
14.1	Cleaning instructions.....	66
14.2	Advices for cleaning.....	66
14.2.1	Eurofoil atomizers.....	66
14.2.2	Warm water.....	66
14.2.3	Rinsing.....	66
14.3	Cleaning the sprayer.....	67
14.3.1	Beginning of spraying season .....	67
14.3.2	Emptying of residual amount .....	67
14.3.3	Procedure for cleaning the tank .....	67
14.3.4	Rinsing boom system and flow gauge (Quick Clean).....	68
14.3.5	Daily cleaning.....	68
14.3.6	Cleaning when changing plant protection product .....	68
14.3.7	Exterior cleaning.....	68
14.3.8	End of spraying season .....	68

14.3.9	Antifreeze protection .....	68
14.3.10	Other winter preparation tips .....	69
<b>15</b>	<b>Cleaning procedures .....</b>	<b>70</b>
15.1.1	Good advise for cleaning .....	71
<b>16</b>	<b>Troubleshooting .....</b>	<b>72</b>
<b>17</b>	<b>Appendixes.....</b>	<b>74</b>
17.1	Wiring diagram for installation kit .....	74
17.2	The sprayers liquid and valve system.....	75
<b>18</b>	<b>Hydraulic diagram.....</b>	<b>76</b>
<b>19</b>	<b>Notes.....</b>	<b>77</b>

# 1 Congratulations with your new danfoil field sprayer

Dear danfoil customer,

Congratulations with your new danfoil air sprayer. We are happy that you have chosen danfoil's unique spraying technology. Danfoil have always represented innovation within field sprayers, and with danfoil's technology you are ensured high capacity, low liquid consumption and better spray economy. As danfoils products must live up to our high expectations to quality we are confident that your new field sprayer will live up to your expectations and demands as well.

Our service team and resellers are at your disposal at all times in case you have any questions regarding your sprayer, want a service check or if you, against expectations, have any problems with your sprayer. We recommend that you at least every second year have a service check on your danfoil sprayer, so that it is always up-to-date and ready to be used.

In order for you to be able to capitalize on the advantages of your new danfoil sprayer from the beginning, it is important that you acquaint yourself with the construction of the sprayer, mode of operation, and settings.

Therefore we recommend you to read this instruction manual carefully before you start using the sprayer.

Also read the instruction manual applicable for the monitor, which is mounted on the sprayer

## Enjoy

## 2 EF declaration of conformity

### Manufacturer:

Company name: **danfoil a/s**

Address: Jellingvej 14

Postal address.: 9230 Svenstrup J

Country: Denmark

Telephone: +45 98 67 42 33

Fax: +45 98 67 34 88

Hereby declare that

### Machine:

Make: **danfoil**

Type: ECCII

Serial number: ECCIIXX/XXXX

Is in agreement with the regulations in RÅDETS DIREKTIV of 14. of June 1989 concerning mutual rapprochement of member states legislation about machines (89/392/EØF with later adjustments) with reference to the directives appendix I about significant security and health requirements regarding construction and production of machines.

May only be coupled with a tractor approved in accordance with all relevant regulations

Svenstrup, the xx / xx 20xx

**danfoil a/s**

Martin D. Sørensen

Technical director



### 3 Machine data

#### 3.1 Machine Data of your new danfoil Sprayer

<i>danfoil sprayer type</i>		ConCorde	
Machine no.	ECCII <sup>xx</sup> / <sup>xxxx</sup>	Year of construction	20 <sup>xx</sup>
Matrix no.		E – Number	
Working width:		<sup>xx</sup> Meter	
Number of sections:		<sup>x</sup>	
Suction filter Type	Arag	Mesh count:	50 mesh / Blue
		Part number:	90320040
Pressure filter Type	Arag	Mesh count:	100 mesh/ Green
		Part number:	90320113
Tank filter Type	Arag	Mesh count:	18 mesh / Black
		Part number:	90320360
Nozzle filter	TeeJet	Mesh count:	50 mesh / Blue
		Part number:	90326002
Technical residual amount:			
Pump Type/Output:	Annovi/Reverberi AR 160		
Sprayer computer Type:	Danfoil Spray Controller (DSC)		
Oil for liguid pump	SAE 10W-40 (alternatively the tractors motor oil)		

Service weight:	3.500 Kg
Weight total:	6.500 Kg
Maximum weight at coupling point:	1.000 Kg
Authorized maximum speed	40 Km/H

### 3.2 Safety notes and warning signs



Before operating the machinery the instruction manual must be read.



The machine must not be used until the operator has received training from trained personnel.



The machine may only be used by personnel with a valid spray certificate.



No personnel other than the operator must be around the machine during operation.



The machine must stand on level ground when folding and unfolding the boom.



Risk of being wedged or pushed when staying under or next to the boom while folding in or out.



No folding of the boom while driving.

Absolute caution to overhead power cables when folding the boom. Always maintain adequate distance.



Danger of being wedged in. Never go over to the machine as long as the tractor engine is running.



When driving in the field, other than when spraying. The boom must be in transport position.



Entering the tank is prohibited at any time.

Poisonous vapours may cause intoxication.



The document holder mounted on the sprayer must contain a description of which chemicals are transported in the tank.



The machines must only be left on firm, sustainable surface and with an empty tank.



Risk of unintentional movement of field sprayer. When parking the sprayer, please make sure placing the scotch at the wheels.



The sprayer must under no circumstances be lifted in points other than those designated



There is no requirement for hearing protection for the operator, as noise levels are far below the requirements in EN 1553 5.1 and D4.

### 3.3 Information plate

There is a CE identification plate mounted on the left side of the frame under the stair. This state the producer, model, model number, year, and weight.



### 3.4 Transport on public road

When driving on public roads or other areas, where traffic law applies – or areas with specific rules and regulations regarding lights and markings on the vehicle, these rules must be complied and the vehicle must be equipped with lights etc. according to the rules.



**Trackcontrol must be in the locked position during transport on the road.**

### 3.5 Lifting points

When lifting the sprayer with a crane the sprayer must be lifted in the designated lifting points as shown in the two images. Be aware that the sprayers must be lifted on both sides to give a homogenous lift.

Lifting points 1 and 2:

Strap is attached at yellow fixture and chassis



Lifting points 3 and 4:

Strap is attached at upper parallel lift arm and chassis on sprayer.



**The sprayer must under no circumstances be lifted in points other than those designated.**



**When transporting the sprayer on a trailer the boom must be tightened down and secured to the trailer.**

## 4 Connection procedures



**BEFORE USING THE SPRAYER. THIS INSTALLATION PROCEDURE MUST BE REVIEWED. FAILURE TO FOLLOW THIS CONNECTION PROCEDURE WILL VOID THE WARRANTY OF THE SPRAYER.**

### 4.1 Connecting the power and control computer in the tractor

To the right is the installation kit. It must be securely mounted on the back of the tractor so that the sprayer's electrical connection can be connected to the box (d). The box must be placed so that the wires face down.

The three red wires must be connected directly to the battery positive terminal.

The two black wires must be connected directly to the battery negative terminal.

Cable (a), (b) and (c) go to the tractor cabine.

Cable (a) connects to a random terminal on the joystick.

Cable (b) Connects to the DSC-screen cable.

Cable (c) connects to the tractors iso socket.

The sprayer is supplied with wheelspeed- and ignition signal through the tractors iso socket.

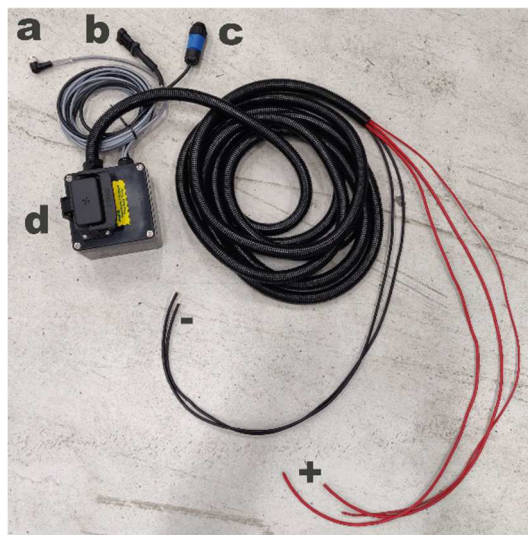

**It is vital that all power wires are connected directly to the battery to avoid power shortage.**

### 4.2 Connection of Load Sensing (LS)

A danfoil ConCorde trailer sprayer is equipped as standard with LS proportional hydraulics which drive the fan, pump, and all remote hydraulics. Depending on the model. There are different requirements for the tractor's hydraulics. Overall, there are 3 standard model variants:

#### **ConCorde 20-28 meter 2-part boom**

The tractor must be capable of delivering 85 L/min at 190 bar.

#### **ConCorde 30-36 meter 3-part boom**

The tractor must be capable of delivering 90 L/min at 190 bar.

#### **ConCorde Combi machines**

The tractor must be capable of delivering 110 L/min at 190 bar.



**If the tractor cannot provide sufficient oil pressure. It can lower the maximum air pressure of the sprayer. It can also affect the performance of the boom control.**

The tractor must be equipped with a 3/4" pressure-free oil return line directly to the oil sump. For tractors with LS (Load Sensing) sockets, this must be prepared for use. The end user's tractor must be equipped with the following:

- LS Load Sensing hydraulic system
- 3/4" male return, 3/4" female pressure
- 1/2" male drain directly to oil sump/pan (MAX. 1 bar back pressure)
- 3/8" female LS signal



**Please note that this should preferably be available at 1500 rpm so that the engine speed of the tractor can be kept below 1500 rpm during spraying to minimize noise nuisance.**



**The back pressure in the drain hose at full load on the hydraulic system must not exceed 1 bar.**

### 4.3 Hydraulic hoses and couplings on sprayer

Danfoil ConCorde is equipped with the following hoses and couplings as standard:

<b>Sprayer is equipped with</b>	<b>(Danfoil Part number)</b>
1: Drain 1/2" Quick connect, female Type ANV12GASF	(90510304)
2: LS signal 3/8" Quick connect, male Type ANV38GASM	(90510311)
3: Pressure P-line 3/4" Quick connect, male Type ANV34GASM	(90510309)
4: Return T-Line 3/4" Quick connect, female Type ANV34GASF	(90510312)
<b>Tractor must be equipped with</b>	
1a: Drain 1/2" Quick connect, male Type ANV12GASM	(90510032)
2a: LS signal 3/8" Quick connect, female Type ANV38GASF	(90510308)
3a: Pressure P-line 3/4" Quick connect, female Type ANV34GASF	(90510312)
4a: Return T-Line 3/4" Quick connect, male Type ANV34GASM	(90510309)





**When connecting and disconnecting the hydraulic hoses. The tractor engine must always be turned off.**

#### 4.4 Connecting hydraulic brake

Connecting the hydraulic brake is done by connecting 1 pcs. ½” brake quick coupling, female ISO56 to the tractors brake outlet. It is required that the tractor is equipped with a trailer brake valve which is connected with the tractors hydraulic and brake system. By depressing the tractors brake pedal the sprayers brake is also activated. In this way the braking is happening safely and effectively.



#### 4.5 Connecting hydraulic stand

Connecting the hydraulic stand is done by connecting two ½” quick couplings, Male type NV to the tractors remote outlet. The hydraulic stand is operated via the tractor.



#### 4.6 Connecting to tractor



**The tractor must be turned off when hooking and unhooking the sprayer**



The sprayer is connected to the tractor and the hydraulic hoses are mounted in the correct outlets on the tractor. Please ensure that the hoses can move freely and do not get caught when the sprayer turns.



Then mount the sprayer's electrical connector on the installation box mounted on the back of the tractor. Please ensure that the plug is mounted vertically and the cable faces downwards as shown in the picture.



Make sure that the ISO connector is connected in the tractor. It is through the ISO connector that the sprayer receives speed signal and ignition signal. It is possible to mount a wheelspeed sensor on the sprayer as an alternative to the ISO connector.

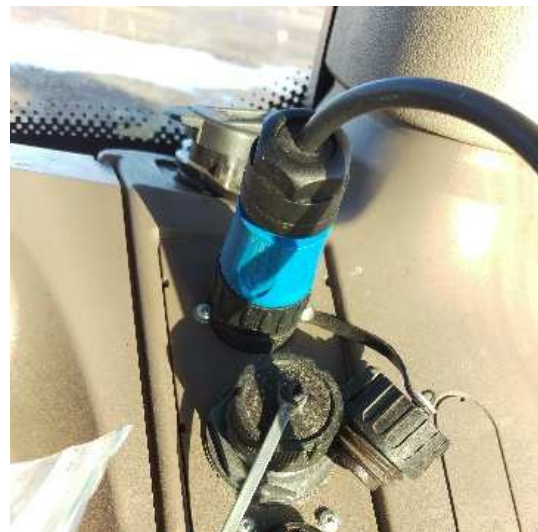

If the sprayer is equipped with trackcontrol, mount the spring in one hole on the tractor. Possibly, loose chain is removed so that it can not get stuck.

In order for the trackcontrol to work as intended, it is important that the spring is tensioned and that there is a minimum of 5 cm of chain to achieve a sufficient deflection on the potentiometer.



## 5 Application of the sprayer

The danfoil sprayers are developed especially for spraying agricultural and horticultural crops. The sprayer is also suitable for forestry, garden centres and other crops.

The danfoil sprayer is designed to disperse all commonly used pesticides at an incredibly low water consumption (usually 30 to 60 l/ha compared with traditionally 150 to 400 l/ha). For a number of spraying tasks the quantity of pesticides being used is noticeably decreased, when comparing to traditional sprayers, and still achieve the same effect. Spraying with a danfoil sprayer is described in detail in **chapter 13**, including directions for dosage, volume of water, and speed.

### 5.1 Danfoil spray technology

#### 5.1.1 Innovation – still

The danfoil sprayer, with the patented atomizer technology, represents innovation within the area of field sprayers. The principle was introduced in 1984 and has been developed subsequently. The danfoil sprayer is an air spray, that is, it uses air as a medium to create fine droplets, unlike the traditional hydraulic sprayer and air-assisted sprayer. The danfoil system is, because of the special patented principle, very environmentally friendly thanks to a reduced consumption of chemicals. Additionally, the operating economy is significantly improved compared to conventional sprayers. The reason for this is partly because water consumption is reduced (increased capacity per tank full), partly because the chemical consumption is reduced, and partly because the atomizers are not changed as with conventional sprayers, where these wear out or the spray tasks are changing.

#### 5.1.2 Drift reduction approval

The Eurofoil nozzle has the following approvals on bare ground. Carried out and approved by the Julius Kühn Institute, Braunschweig..

Drift reduction	Air pressure	Water volume	Boom height	Speed
90%	4 mbar	50 l/ha	40 cm	6 km/h
75%	5 mbar	50 l/ha	40 cm	6 km/h

#### 5.1.3 Danfoil sprayer operation

The first hydraulic field sprayers in Europe saw the light more than 100 years ago and the basic components of the conventional field sprayers have not changed over the last several decades. They all have tank, pump, hoses, pipes, and nozzles. The conventional sprayers' mode of operation is that hydraulic pressure is used to press liquid through a small hole in the nozzle, whereby the liquid is atomized and spread.

The Danish produced danfoil sprayer, which is an air-sprayer, represents with the patented atomizer principle innovation with the area. Similar to the conventional sprayer, the danfoil sprayer have a tank, pump, and pipes, but no nozzles. Instead of nozzles, which are available in numerous sizes and shapes for conventional sprayers, there is only one atomizer for a danfoil sprayer. The task of the atomizer is to distribute the liquid. Immediately before the atomizer, the liquid is throttled and thereby controlled. The spray liquid is atomized by pressing air over the foil and droplets are created from the lower edge of this. The sprayer is therefore an air blower, which through a glass fiber/aluminum pipe creates and overpressure in the atomizer.

### 5.1.4 Deposit of liquid at top and bottom

When spraying on open field, with little or no crops, air ensures that the droplets reach the soil and spread through horizontal air movement. In a larger crop the air, which create turbulence around the plants, ensures that liquid deposits in both the top as well as the bottom of the crop. In contrast, conventional sprayers deposit the majority of the liquid on the top of the crop, on the upper side of the leaves. The deposit of liquid on the underside of the leaves makes it easier for pesticides to penetrate and thereby be effective.

**Difference between danfoil Eurofoil® atomizer and the conventional nozzle:**

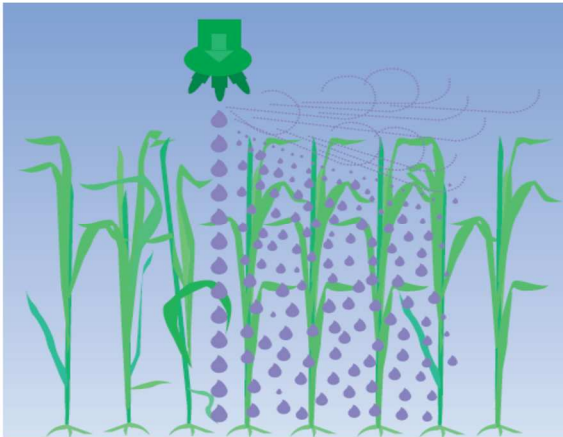
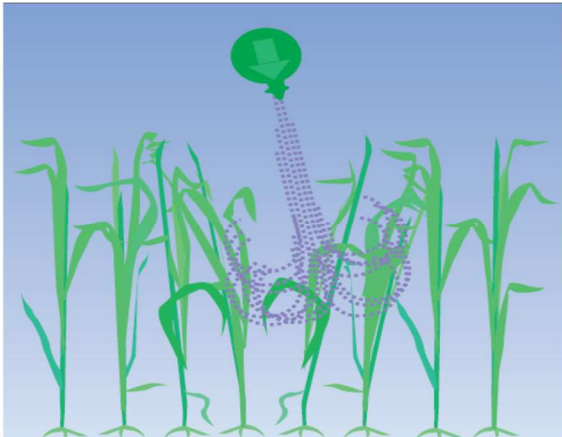
Conventional Nozzle	Danfoil Eurofoil Nozzle
	
<p>Very small droplets can be difficult to control. They hang in the air like a fog that in calm weather will stretch like a long "tail" after the sprayer. Even very light winds can lead such fine drops astray.</p> <p>The drift is greater over low and open crops than over high densities that can catch the droplets.</p>	<p>The Danfoil sprayer mixes liquid and air in the atomizer. An air stream tears the spray liquid into droplets and carries them down into the crop. The air velocity that determines the droplet size can be varied.</p> <p>Thanks to the high speed of the droplets, the drift is reduced and the crop is hit more precisely.</p>

### 5.1.5 Greater timeliness and more spray hours

As the droplets are ejected from the atomizer at high speed, they are not as susceptible to drift. It provides more spraying hours in the field and ensures that spraying can be carried out safely - even if it blows too much for proper spraying with a conventional sprayer.

### 5.1.6 Reduce consumption of chemicals

Using the danfoil system ensures an effective spraying and large capacity. It is for a variety of spray tasks possible to reduce consumption of chemicals compared to the amount used with a conventional sprayer. See **chapter 11** for a detailed description of the possibilities for reductions with you danfoil sprayer.

This can be done by choosing lower dosages or by selecting the same dosage, where possible, and reduce treatment frequency. The good use of the spray liquid is achieved by a low water consumption of 30 to 60 l/ha, compared to 150 to 400 l/ha for conventional sprayers thus the danfoil sprayer provides savings in time, chemicals, and water – to the benefit of both the user and the environment.

## 6 Operation of the sprayer's functions

The functions of the sprayer are operated almost exclusively through the screen in the tractor. Please read the manual for the control for more information about these functions.



**Please read the manual for the control before using the sprayer.**

### 6.1 Filling with water

Filling with water is done through the two couplings on the left side of the sprayer in front of the step board. The first coupling (Front/left) fills the main sprayer tank. Second coupler fills the clean water tank. The yellow tank for handwash is filled through the blue lid at the top.



**If the sprayer is equipped with automatic filling equipment, this must be activated through the DSC-screen. See the control manual for a description.**

### 6.2 Chemical filler

To facilitate and make the chemical filling safer, the chemical filler should be used. The pesticide is filled into the container, after which it is pumped into the tank.

The Chemical filler is activated on the yellow button to the right of the step board.

- 1: Press the button in and it starts flashing.
- 2: Open the lid and activate the yellow handle on the side of the chemical filler. This will start a rinse. Activate if necessary the red handle to start the nozzle at the bottom.
- 3: Turn the red handle at the bottom of the filler to start flushing.
- 4: Chemistry can be filled into the chemical filler.
- 5: The tank cleaner in the chemical filler is activated with the black handle. This enables you to clean the chemical filler internally.
- 6: Now perform a thorough cleaning of the chemical filler.
- 7: Now press the yellow button again and see that it





flashes faster. This means that clean water now flows through the chemical filler.

8: Now thoroughly clean the chemical filler. By default, the sprayer is set to 20s. with clean water.

9: When the yellow button starts flashing quickly, the red valve at the bottom of the chemical filler should be closed.



**Note that the amount of clean water used to wash the chemical filler enters the main tank.**



**Note that all water-soluble granules MUST be mixed in the chemical filler.**

### 6.3 Washing after use

A danfoil sprayer should not be cleaned - it should be kept clean. It is therefore important that the user is thorough with this, to avoid any possible blockages in the system. Read more in chapter 14 Cleaning the sprayer.

The sprayer is equipped with 3 different washing programs. They can be activated through the DSC-screen:

1: **Boom flush**, this program can be used to advantage when there is a short stop in work. With this washing program, only the boom is cleaned.

2: **Pump wash**, this program is used for longer stops where there is a need to store mixed plant protection in the main tank.

3: **Tank wash**, this program is used after all plant protection has been applied and a total cleaning of the sprayer is desired. This program can be run several times, for further cleaning.



**Read in the manual for the control how the individual washing programs are activated.**

## 7 Description of danfoil sprayers elements

In this chapter, the most central elements of a danfoil ConCorde trailer sprayer are reviewed.

### 7.1 Hydra Pro hydraulic system



See chapter 4.2 for connection of Connection of Load Sensing (LS)

Danfoil ConCorde is equipped with the new Hydra Pro hydraulic system as standard. The system is an LS proportionally controlled hydraulic system which drives the fan, pump and all remote hydraulics. This means that the sprayer does not require a PTO connection, which significantly facilitates the mounting of the sprayer on the tractor. Likewise, the system is also very service friendly, and requires a minimum of maintenance.

A hydraulic diagram for the sprayer can be found in Chapter 18 Hydraulic diagram.

The hydraulic system consists of the following components:

- 1: Coupling hoses for connecting with tractor
- 2: Oil filter
- 3: LS controlled PVG valve
- 4: LS controlled Rexroth valve
- 5: Fan motor
- 6: Hydraulic cylinder
- 7: Oil motor

#### 7.1.1 Couplings to connecting with tractor

Further information on this can be found in 4.2 Connecting of Load Sensing (LS).

#### 7.1.2 Oil filter

The hydraulic system is equipped with an oil filter. This prevents any impurities from entering the sprayers hydraulic system. The oil filter is located behind the main pump in front of the sprayer.

It is **IMPORTANT** that the oil filter is checked regularly and it is recommended to change it min. every 2 years.

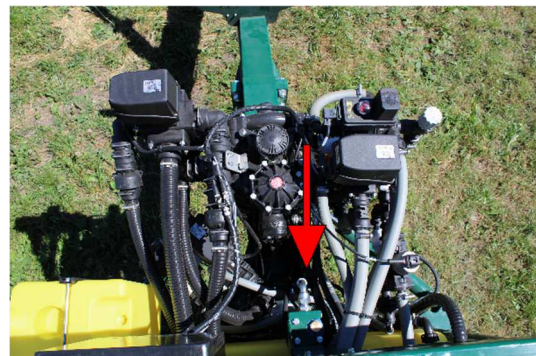

#### **Service interval:**

**Oil filter is changed after the first spraying season and then every 2 years.**

### 7.1.3 LS controlled PVG valve

The PVG32 valve from Danfoss is a very reliable LS controlled hydraulic valve. The valve controls the two fans at the back of the sprayer, the oil pump that drives the liquid pump and the trackcontrol (option).

The valve is equipped with a test nipple for measuring oil pressure. There are also LEDs on the electrical modules.



### 7.1.4 LS controlled Rexroth valve

The LS controlled Bosh Rexroth valve on the back of the sprayer controls all the functions of the boom. Tilt, up / down as well as individual hydraulic functions are all proportional, this means that the speed of these cylinders can be controlled by the boom control. It provides a very stable and calm boom movement that ensure good boom placement.



### 7.1.5 Fan motor

The fan motors that create the air pressure in the boom are located inside the air distributor which is located on the back of the sprayer. The air is sucked in through the grate at the top of the fan box and pushed out through the boom. The grate at the top of the fan box must be cleaned as needed.

At times, it may be necessary to install a fine-mesh suction filter (item number 90330995), which prevents smaller particles and flies from being sucked in and getting stuck in the atomizers. It is only recommended to have this extra filter fitted when needed, as it reduces the maximum air pressure in the boom.





### 7.1.6 Hydraulic cylinder

The sprayer is equipped with several hydraulic cylinders. These are used to control the moving parts of the sprayer. It is important that these cylinders are undamaged, and in the event of leaks, the gasket set should be replaced. In connection with moving parts, smaller nipples are fitted. All grease nipples must be replenished with grease every week so that the moving parts can slide freely.



**Service interval:**

**Refilling grease nipples with grease must be done once a week.**

An overview of the lubrication points can be found in Chapter 11 Lubrication and maintenance scheme.

### 7.1.7 Oil motor

A hydraulically driven oil motor is used to drive the liquid pump. The oil motor is driven by the PVG32 valve and is mounted on the back of the liquid pump.



**Service interval:**

**Oil in the liquid pump is changed every year.**

**Oil type is SAE 10W-40 (alternatively the tractor engine oil is used)**



**Service interval:**

**If the sprayer runs many hectares, the diaphragms in the liquid pump can advantageously be changed every year. Alternatively, every 2 years.**

### 7.1.8 Hydraulic stand

When the danfoil ConCorde trailer sprayer is not mounted on a tractor, the sprayer rests on the hydraulic stand. When the sprayer is in use, the stand is pulled up under the sprayer and ensures minimal damage to crops. The stand is controlled via the tractor's hydraulics and is operated via a hydraulic outlet on the tractor.

The hydraulic stand is used as a parking brake when the sprayer is parked (only on level surface)



### 7.1.9 Hydraulic brake

Danfoil ConCorde trailer sprayer is fitted with hydraulic brakes which ensure maximum safety during transport. When depressing the tractor's brake pedal, the sprayer's brakes are activated accordingly, so that braking takes place safely and efficiently. The braking system requires the tractor to be equipped with a special trailer brake valve which is connected to the tractor's hydraulic and braking system.



### 7.1.10 Air suspension on wheel axle

Danfoil ConCorde trailer sprayer is mounted with air suspension on the wheel axle. The air suspension ensures a stable boom when spraying in the field. When driving on the road, the air suspension creates a safe driving, especially with a full tank on uneven roads. The air suspension is mounted as shown in the picture to the right. The air bellow spring must be inspected at regular intervals to ensure that it has not lost air and for cracks and deterioration. When refilling air, use the valve on top of the air cushion. 6 bar pressure must be filled as standard. (empty tanks and boom in transport position)

**Service interval:**

**Air bellows are checked weekly for correct air pressure. Adjust to 6 bar before use when the sprayers tanks are empty.**

## 7.2 Liquid system

The sprayer's liquid system on a danfoil Concorde is made up of the following components:

- 1: Suction side canbus valve
- 2: Suction filter
- 3: Liquid pump
- 4: Safety valve
- 5: Relief valve
- 6: Pressure side canbus valve
- 7: Motor valve
- 8: Pressure filter
- 9: One-way valve
- 10: Flowmeter
- 11: Section valves

### 7.2.1 Suction side canbus valve

A canbus controlled suction valve is fitted, which determines where the pump is to suck liquid from. It is possible to suck liquid from:

- 1: Sprayer tank/main tank
- 2: Clean water tank
- 3: External fill coupling
- 4: Front tank

The Canbus valve is electronically monitored, and in the event of a fault, the user is informed of this on the screen in the tractor.

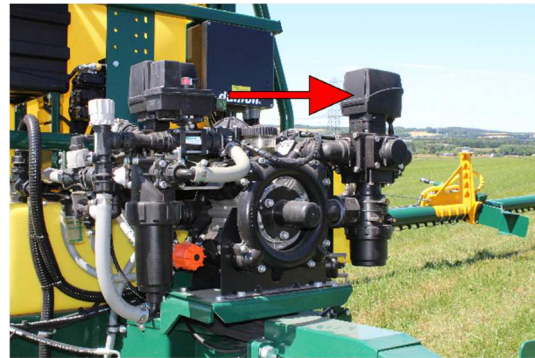

**The suction side canbus valve must be retightened to 8Nm at regular intervals to ensure that it does not leak.**

### 7.2.2 Suction filter

The suction filter is mounted under the suction valve just before the liquid flows into the pump. The function of the suction filter is to filter out larger particles. The filter must be cleaned at regular intervals and must be changed once a year. The filter is a mesh 50 and has part number 90320040.



**When cleaning the pressure filter, the liquid pump MUST be switched off so that there is no pressure in the liquid system.**



**Service interval:**  
It is recommended to replace the filter before each spraying season.



### 7.2.3 Liquid pump

The liquid pump, located at the front of the sprayer, transports the liquid from the tank to the boom. The pump is a diaphragm driven piston pump with 4 chambers and can therefore run even without water. All pump parts that come into contact with the spray liquid are made of plastic-coated aluminum and stainless steel.

The lifespan of the pump-diaphragms is drastically reduced if it sucks vacuum, so make sure the suction side of the pump is never blocked.

The liquid pump on the danfoil sprayer is oversized to ensure long life, but the performance will decrease continuously over time. This is because of material fatigue of the pump's 4 membranes, which is why they should be replaced (item number 90320048B).

The liquid pump is equipped with an oil level glass. It is IMPORTANT that the amount of oil in the glass always stays above the minimum mark. The glass is refilled with SAE 10W-40 (Alternatively the tractor engine oil).

In addition, it is IMPORTANT to check the color of the oil, if it is gray / white, the membranes of the liquid pump must be checked, all 4 membranes should be replaced at the earliest opportunity.



**Service interval:**  
 The oil level on the pump must be inspected regularly and refilled as required.



**Service interval:**  
 At low performance or gray / white color in the oil glass, the pump diaphragms should be inspected.

### 7.2.4 Safety valve

The liquid pump is equipped with a pressure relief valve, which is a safety valve in relation to a defective valve or blockage in the fluid system. The pressure relief valve is preset from danfoil and must **NOT** be re-adjusted.



The safety valve is **NOT** to be readjusted

### 7.2.5 Relief valve

The fluid system is provided with a pressure relief valve which relieves the fluid system. The amount of relieved fluid is returned through the pressure filter and helps to keep it clean.



The relief valve is **NOT** to be readjusted.

### 7.2.6 Pressure side canbus valve

A canbus controlled pressure valve is fitted, which determines where the pump is to direct the liquid. It is possible to pump the liquid to:

- 1: Sprayer boom
- 2: Chemical filler
- 3: Tank cleaning
- 4: Sprayer/main tank (pressureless)

The Canbus valve is electronically monitored, and in the event of a fault, the user is informed of this on the screen in the tractor.

The valve is controlled automatically through the selected operating mode from the DSC-screen.

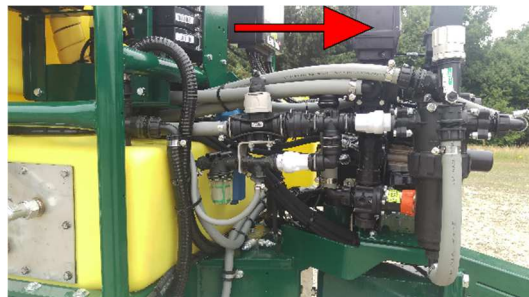

**The pressure side canbus valve must be retightened at 5Nm at regular intervals to ensure that it does not leak.**

### 7.2.7 Motor valve

The sprayer is equipped with a motor valve that regulates the liquid flow to the boom depending on the selected l/ha as well as the forward speed. The excess liquid is returned to the tank and used for stirring. On top of the motor valve is a small sight glass which indicates the position of the valve.

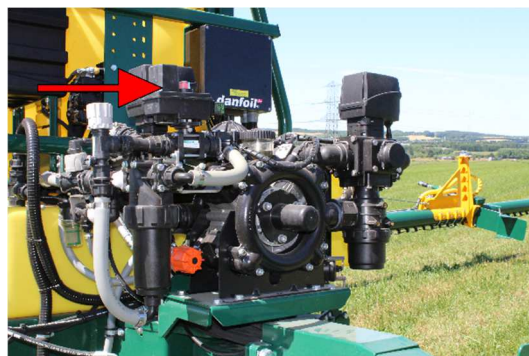

**Do not disassemble the motor valve.**

### 7.2.8 Pressure filter

The pressure filter is the most important filter on the sprayer and must be checked frequently. The filter must be replaced once a year. The filter is mounted on the right side of the liquid pump. The filter has a built-in self-cleaning function that helps keep it clean.

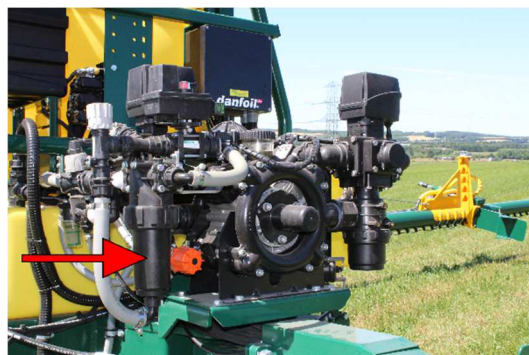

**Service interval:**  
 The pressure filter is checked frequently and must be replaced before starting the spraying season.



When cleaning the pressure filter, the tractor must be turned off.

### 7.2.9 One-way valve

To ensure that spray liquid cannot flow back through the liquid pump, a one-way valve is located after the pressure filter. This valve must be replaced every 2 years.

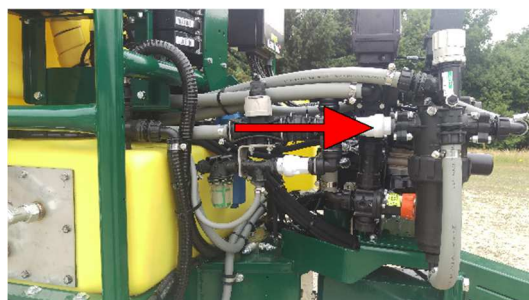

**Service interval:**  
 The one-way valve must be replaced every 2 years.



### 7.2.10 Flowmeter

The sprayer is equipped with a flow meter that measures the liquid flow out to the boom. The flowmeter measures the flow through magnetism.

The flowmeter in correlation with the motor valve makes sure that the selected l/ha is always obtained

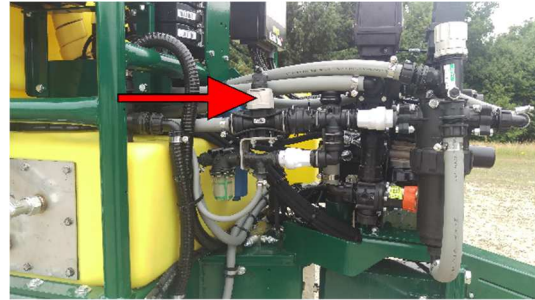

**Service interval:**  
 Check as needed. Residues can be wiped off with a clean, soft cloth.



Typically no recalibration needed

### 7.2.11 Section valves

The sprayer is equipped with a number of section valves. The section valve has the task of opening and closing the sections on the boom you wish to operate. The section valves are canbus controlled and if an error occurs, it will be reported to the DSC-screen.

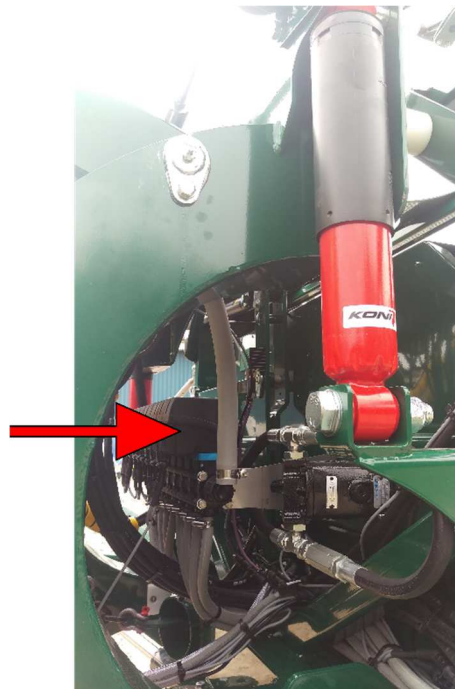

## 7.3 Clean water pump

It is important to flush the boom when there is a break in the work, for this purpose a separate clean water pump is fitted.

The clean water pump is mounted on the left side of the sprayer, by the step board. The pump is very powerful and ensures great flow through the boom when cleaning.



The clean water pump has a pressure filter, part number 90320419. The filter must be inspected at regular intervals and should be changed once a year together with the other filters on the sprayer.

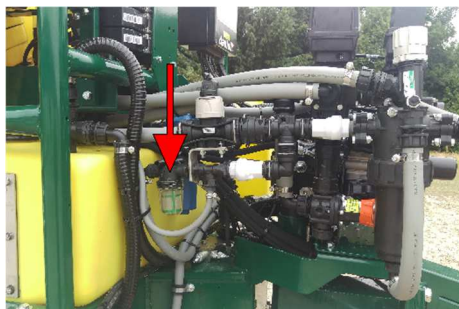

To ensure that spray liquid cannot flow back through the clean water pump and into the clean water tank, a one-way valve is located after the pressure filter. This valve must be replaced every 2 years.



**Serviceinterval:**  
**The one-way valve must be replaced every 2 years.**

## 7.4 Liquid Tanks

The ConCorden is equipped with three water tanks, the main/sprayer tank of 3000l for storing the spray liquid, the clean water tank which is used for cleaning and the hand wash tank which is used for hand washing.

### 7.4.1 Sprayer tank 3000 liter

The trailer sprayer comes with a 3000 liter spray tank made of impact-resistant polyethylene. The tank has a streamlined design and there is easy access to the filling cover from the platform in the front of the sprayer. The design is also characterized by the fact that there are no sharp edges, which ensures optimal cleaning of the tank. The sprayer is as standard equipped with a tank sensor that measures the liquid level in the tank. However, it is possible (option) to have a manual tank gauge mounted on the right side of the sprayer's front



### 7.4.2 Clean water tank

Danfoil ConCorde is fitted with a 270 liter clean water tank located under the platform in front of the spray tank.

Filling is done to the left of the step board. It is important to ensure that the clean water tank is always full. An overflow protection has been made on the tank which indicates when the tank is full.

A hydraulic oil cooling spiral is mounted in the clean water tank where the return oil runs through before it runs back to the tractor. It cools the hydraulic oil while heating the water in the clean water tank. The hot water increases the cleaning effect considerably.



The clean water tank **MUST** always be filled to ensure cooling of the hydraulic oil.

### 7.4.3 Hand wash tank

A 15 liter tank is mounted on the left side of the sprayer for hand washing. The water in the tank is intended for washing hands, protective equipment, filters and the like. Only fill the container with clean tap water.



**The water in the container must not be used as drinking water.**

### 7.5 Control electronics

The sprayer is equipped with the DSC control. A modern approach to spray controls which is robust and simple. Read the separate manual for the DSC control for more information about the use.



**Read the control manual before using the sprayer.**

The electrical system consists of the following components:

- 1: Installation box
- 2: Installation in the tractor
- 3: Master control box
- 4: Slave control box
- 5: Canbus valves



### 7.5.1 Installation box

The installation box must be installed on the tractor. It is the electrical connection point between the tractor and the sprayer.

The Installation box must be mounted so that the cable from the sprayer faces downwards.

It is important that the supply lines are routed directly to the tractor's battery. The remaining wires are inserted through the rear window of the tractor.

There are fuses in the installation box.



**There are fuses in the installation box.**

### 7.5.2 Installation in the tractor

The devices used to control the sprayer are a monitor and a joystick. The DSC-screen and joystick must be mounted inside the tractor in a suitable place.

It is possible to upgrade the screen to a 7" screen as shown in the picture. The standard joystick shown in the picture can also be upgraded to a comfort joystick.

It is possible to connect different types of GPS to the sprayer, and the sprayer can also use the tractor's built-in GPS via ISOBUS - however, this is an option.



### 7.5.3 Master control box

The master control box is mounted in front of the step board on the left side. This control box handles most of the sprayer's functions and can be expanded with an option control box when purchasing options.



There are fuses inside the master control box.

### 7.5.4 Slave control box

The slave control box, which controls all actuators on the boom, is located on the back of the sprayer by the air distributor. It is the box to the left in the direction of travel.



There are fuses inside the slave control box.

### 7.5.5 Canbus valves

Motor valves for liquid as well as section valves are canbus controlled. This means that there is fault monitoring on all essential components on the sprayer, and if a fault occurs, the driver is informed of this on the DSC-screen in the tractor.

## 8 Boom suspension and boom construction



It is important to regularly check the boom tubes for foreign objects that can limit the air pressure and thus create an uneven atomization in the Eurofoil atomizers.



The machine must stand on level ground when folding and unfolding the boom.

The boom construction of the Danfoil ConCorde trailer sprayer is suspended in a very stable pendulum. The air distributor itself is mounted on two parallel arms, which are hydraulically controlled and suspended. All raising, lowering, folding and tilting functions are hydraulically controlled and operated via the sprayer computer and joystick in the tractor.

The parallel arms have the function of raising and lowering the boom via the hydraulic pistons on the parallel arms. In addition, the parallel arms have the function of suspending the boom so that it is always stable and at the right height above the crop.

The pendulum-suspended boom construction ensures that the boom is always adapted to the terrain and shock absorbers and limiters are fitted, which ensures a calm boom.

The boom is raised / lowered and tilted from the joystick in the cabine. If an individual boom lift is fitted, the boom can be adjusted while the boom-wings are individually above and below horizontal.



The boom is made of aluminum to ensure a low weight and high strength. The profile of the extruded aluminum ensures a homogeneous weight distribution throughout the length of the boom.

The boom is supported by wires mounted on the boom suspension and in towers mounted after the inner section. For boom adjustment, see chapter **10.2.7 Adjusting the sprayer boom**.

The boom tubes also have the function of transporting the air to the Eurofoil atomizers through the boom tubes. In the unfolded position, the tubes are therefore airtight to maintain the air pressure. The same applies to reduced working width, e.g 12 meters, where flaps are mounted at the inner boom to seal them off.

The boom is unfolded and folded in via the sprayer's hydraulics and operated via the joystick in the tractor.

## 8.1 Air distributor

The air pressure for the Eurofoil atomizers is created via the air distributor, which is located together with the boom suspension on the back of the sprayer. The air distributor is fitted with two fans controlled by two hydraulic motors. The speed of the hydraulic motor controls the air pressure in mbar in the boom. When the sprayer wants to regulate this air pressure, the speed of the hydraulic motors is regulated. It is important to regularly check the air distributor for any foreign objects that may prevent a free air intake.



## 8.2 Safety bolts

The inner boom is mounted on each side with 4 pcs. safety bolts which will snap in the event of a collision with the boom. This ensures that there is no unnecessary damage to the boom, blower box and boom suspension. When replacing safety bolts, the following new safety bolts must be fitted, as shown in the picture to the right:

- 2 pcs. Safety bolts type 8.8 in the top
- 2 pcs. Safety bolts type 8.8 in the bottom



**When replacing safety bolts, corresponding safety bolts MUST be fitted as shown above. Failure to do so will void any warranty and increase the risk of damaging the boom considerably.**

## 8.3 Eurofoil atomizer and anti-drip

The task of the atomizer is to distribute the liquid. Immediately before the atomizer, the liquid flow is throttled, thereby controlling the liquid flow. The spraying of the spray liquid takes place by air being forced past an atomizer plate on which the liquid is located, and droplets are formed from the lower edge thereof. On the sprayer there is therefore an air blower, which through an aluminum tube creates an overpressure in the atomizers.



When spraying on bare soil with no or little crop mass, the air ensures that the droplets reach the ground and are distributed through horizontal air movements. In larger crops, the air which creates turbulence around the plants ensures that spray liquid can be deposited both at the top and bottom of the crop, and on both the top and bottom of the leaves.

The danfoil system ensures efficient spraying and a large capacity of between 30 and 60 liters per hectare.



### 8.3.1 Eurofoil atomizer construction

The Eurofoil atomizer is made of durable plastic and the atomizer plate itself is made of a mixture of plastic and fiberglass. An angle-fitting and a t-fitting are mounted in front of the atomizer, see the picture below. Restrictors are mounted in the angle-fitting and the t-fitting. The restrictor in the T-fitting is a 0.7mm and the restrictor in each angle-fitting is 0.5mm. This ensures an optimal fluid pressure. Restrictors must be checked regularly to ensure that they are not stopped. This is done by checking the fluid flow through the atomizer.

1. Eurofoil atomizer
2. Angle-fitting with 0.5mm restrictor
3. T-fitting with 0.7mm restrictor
4. Anti-drip
5. Filter for anti-drip

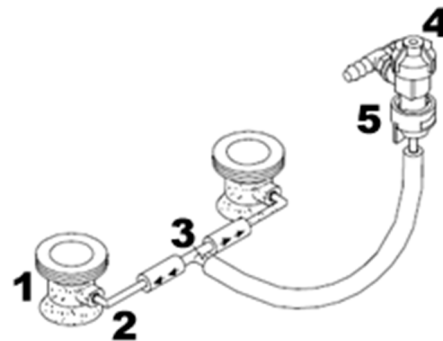

Before the T-fitting, an anti-drip is fitted which ensures that residual amounts in the spray line do not run out. The anti-drip is fitted with a nozzle filter (90326002). The nozzle filter ensures that impurities do not reach the restrictors to prevent blockage.



**The restrictors must be checked regularly for blockages. If the angle- and t-fittings are cleaned with air, this MUST be done in the direction of the fluid flow, otherwise the restrictors risk falling out and an uneven fluid flow is created.**



**The nozzle filter in the anti-drip must be continuously inspected for impurities and possibly cleaned. This ensures optimal fluid flow.**

## 9 Options

Danfoil ConCorde trailer sprayer can be supplied with a variety of options.

### 9.1 End nozzles

A tilted nozzle allows you to spray at an angle at the end of the boom.



### 9.2 Boom control

The self-leveling boom ensures that the desired boom height is always maintained regardless of differences in the field terrain. This allows the operator to concentrate on the spraying work and does not have to continuously adjust the height and tilt of the boom.

The boom control is available in several levels depending on price and performance:

1: **Boom Control**, is suitable for flat terrain with no or few soft hills. The boom only works in the tilt and up / down.

2: **Terrain Control**, is suitable for slightly more challenging terrain where there is a need for the boom-wings to move individually above and below horizontal.

3: **Rough Terrain Control**, is suitable for very hilly terrain. The boom is fitted with a stabilizing gyro technology, which through tilt, up / down and the individual cylinders controls the boom so that it slides at a fixed height above the crop.

The boom is fitted with the Hydra Pro hydraulic system, which is a proportionally controlled hydraulic system. This means that all boom control functions are proportionally controlled.

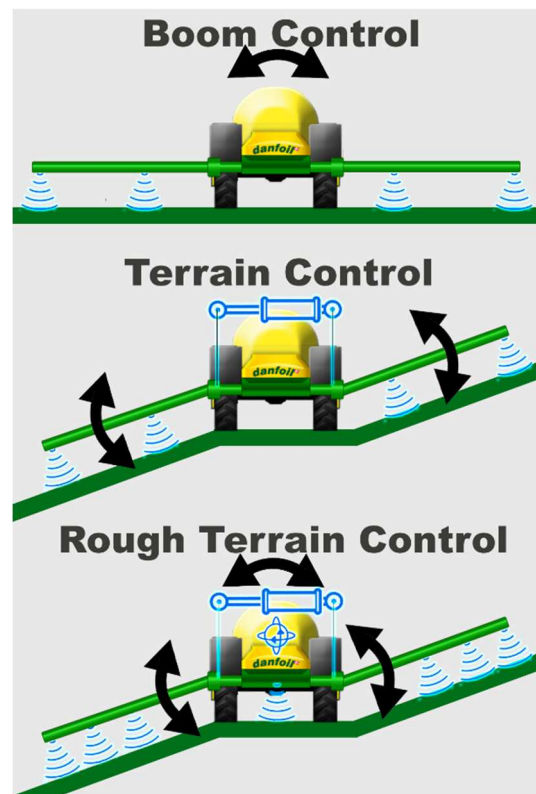



Refer to the sprayer computer manual for setting the Self-Leveling Boom.

### 9.3 Line filters

It is possible to mount an additional filter on each spray section. The filter is green mesh 100.

When spraying with a sparingly soluble preparation, as well as in case of problems with clogging, fitting line filters will solve the problem.



### 9.4 Exterior washing equipment

If there is no washing area on the farm, the solution may be to mount a low-pressure washing equipment on the sprayer. It allows to wash the sprayer in the field. The washing equipment is fed by the clean water pump, which sucks heated water from the clean water tank.



## 9.5 High pressure cleaner

The high-pressure cleaner with hose roller is for use when cleaning the outside of the sprayer in the field with clean water. The high-pressure cleaner uses heated water from the clean water tank and thus ensures efficient cleaning. The pump for the high-pressure cleaner is located to the right of the liquid pump and the high-pressure lance itself is located on the back of the sprayer. High pressure cleaners are activated via the sprayer computer.



**Avoid getting air in the hose for the high pressure cleaner as the pressure will drop. This can happen if the clean water tank runs out of water. In case of air in the system, open the valve on the high-pressure cleaner pump.**

## 9.6 TrackControl – steerable tow

The controllable towbar ensures minimal descent of crops and maintains the wheel track of the sprayer together with the tractor cleaner. The system is built with two cylinders mounted on each side of the towbar. In addition, two sensors are fitted, one in each end of the towbar. The two sensors constantly measure the differences between each other and thus ensure that the sprayer follows the wheel tracks of the tractor. The system is hydraulically controlled and set up via the sprayer computer.



**Refer to the computer manual for setting steerable features.**



**When transporting, steerable tow MUST ALWAYS be in the central locked position.**

## 9.7 Work lights

When the spraying work takes place at times of the day when light is scarce, it is advantageous to buy work light for the sprayer. The light is mounted under the air distributor and illuminates the nozzle image. It gives the driver a good overview of the shower from the atomizers. The light from the work light is very concentrated and can be seen up to 1 km away.



## 9.8 Chemistry cabinet

It is possible to buy an extra cabinet so that chemicals can be brought on the sprayer.



## 9.9 Electronic windspeed sensor

The weather is an important factor during spraying. Therefore it is possible to have an windspeed sensor mounted directly on the sprayer. The driver can then continuously follow the wind speed directly on the screen.





## 9.10 Camera

While driving on the road, it can be an advantage to be able to see the traffic coming from behind. It is therefore possible to mount a camera on the back of the sprayer. During transport, you can then use the DSC-screen to orient yourself backwards.



## 9.11 Underbody protection shield

A protective shield can be mounted under the sprayer, it ensures that the crop slides on a smooth plate and ensures the least possible wear on the plant mass.



## 9.12 Autofill equipment

The autofill equipment facilitates the filling process for the sprayer operator. The autofill equipment measures the amount of liquid and the operator can then enter the desired number of liters he wants to fill in the spray tank, e.g 2000 liters. The autofill equipment closes for supply when the desired amount is reached. The autofill equipment is located in front of the step board.



## 9.13 Ball hitch

The sprayer is equipped as standard with a tow eye Ø50. But can be purchased with a K80 ball hitch. The ball hitch attaches the sprayer to the tractor better and will improve the performance of the steerable tow.

## 9.14 Individual boom lift

Individual boom lift allows the operator to adjust the right and left boom-wings individually via the joystick. This is an advantage on fields with terrain differences and gorges. The individual boom lift is hydraulically controlled and operated via the joystick in the tractor. The booms are adjusted individually via two hydraulic cylinders mounted together with the wires on the boom. This can with advantage be combined to a boom control which can automatically control these cylinders, which provides increased comfort for the driver.



## 9.15 Comfort display

If the display in the tractor is upgraded to the large 7" screen, it is possible to purchase a comfort display for mounting at the step board. It allows you to operate all the functions of the sprayer on the sprayer. It could, for example, be to use the automatic filling equipment.



## 9.16 Air brake system

The trailer sprayer is equipped with hydraulic brakes, but the sprayer can also be fitted with an air brake system.



### 9.17 Extra installation kit

If several tractors are to be able to use the sprayer. It may be an advantage to purchase one or more additional installation kits. The installation kit consists of the connection box to be mounted on the back of the tractor. Thus, only the screen and joystick need to be moved between the individual tractors. It increases flexibility.



### 9.18 Wheelspeed sensor

By default, the sprayer uses the gearbox signal from the tractor. If the tractor is not equipped with one, it is possible to mount a wheel sensor on the wheel of the sprayer. Or possibly, on the wheel of the tractor.



### 9.19 Comfort joystick

The joystick contains 5 proportional functions and 6 digital buttons. Via the 2 proportional rollers on the front of the joystick, the speed of the boom's wings is steplessly regulated - it gives a good control of the boom, which far exceeds what can be achieved through a conventional button control.

On the back of the joystick is another proportional roller which is used for trackcontrol, the roller has Easy Catch Control. Easy Catch Control is a function that makes it easy for the user to grab the trackcontrol out of the automatic tracking - it is especially nice when you have to reverse the sprayer into corners, or around obstacles. It is far superior than just locking the tow bar when reversing.

The tilt and vertical movement of the boom are also controlled steplessly by tilting the joystick to the sides





or back and forth.

The joystick is primarily developed for our larger trailer sprayers.

## 9.20 Large DSC-screen

If the sprayer is upgraded with the large 7" display, the user gets an increased overview of the sprayer's functions. The functions and screens are the same as on the smaller 4.3 "standard display.



## 9.21 Section control GPS

With section control GPS, the section valve control can be controlled automatically via GPS signal from the tractor's built-in GPS, or from an externally mounted GPS. This overrides the manual control of the sections and achieves a more accurate performance. It is possible to pair most ISObus compatible GPSs with the sprayer.



## 9.22 Mechanical deviation joint

The mechanical deviation joint is mounted on the outer boom and ensures that the boom does not break in the event of a collision on the outer part of the outer boom. The deviation joint is mounted as shown in the picture and can only deviate backwards. The joint finds its way back to the starting position.



## 10 Preparation and maintenance of the sprayer

### 10.1 Preparation and inspection of the sprayer

Preparation of the sprayer is important in relation to the durability of the sprayer and in relation to an optimal spraying every time. In this chapter, the adjustment of the boom before starting, the lubrication procedure and the general check before starting the sprayer are reviewed.



**No personnel other than the operator must be around the machine during operation.**



**During inspection, lubrication and maintenance, the sprayer must be placed on the support leg on a solid surface and the tractor engine must be stopped and the key removed from the ignition switch.**



**It is important to make sure that all guards are in place and intact before starting the sprayer.**

### 10.2 Before spraying

#### 10.2.1 General inspection of the sprayer

Check the air pressure in the tires and retighten the wheel nuts after the first 2-4 hours of driving and then retighten them on a weekly basis.

A small yellow arrow is mounted on all wheel nuts. It is checked every day before start-up that they all point towards each other. That way, you can easily see if a nut has been loosened.



Check the oil level in the liquid pump via the oil level glass on the liquid pump. If necessary, top up with SAE 10W-40 (alternatively the engine oil used by the tractor).

Check all hydraulic functions on the sprayer, including folding in and out, raising / lowering and tilting the boom.

Important: the booms must be unfolded with the sprayer standing on a level surface and the tilt standing in the neutral position.

### 10.2.2 Filling with water

The water is filled in the tank via the filling couplers by the ladder. The water in the clean water tank is replaced at each filling, as it is used to cool the hydraulic oil.



**Remember that if filling directly from the water pipe, this must be fitted with a non-return valve to avoid backflow to the water supply.**



**Remember to fill a minimum of 1/3 of the water in the tank before filling with chemicals.**



**It is only recommended to use water from a water plant, if water from a buffer tank is used, it is recommended to mount a filter on the water supply.**



**It is important to check the hardness of the water to avoid problems with clogging the sprayer.**



**It is important to check the pH of the water to ensure that it is correct in relation to the agents used.**

### 10.2.3 Inspection of functions for spraying liquids



**When the tank has been filled with water, but before adding pesticides, all the liquid functions of the sprayer must be tested and checked.**

Suction and pressure filters are cleaned and checked. The nuts must only be tightened by hand. If this is not sufficient to seal it, check if the gaskets are damaged. if necessary, grease with a little silicone-grease.

Check that there is sufficient agitation in the bottom the tank.

Fluid hoses are checked for leaks.

Anti-drips are checked.

The liquid flow from the atomizers is checked, and at least once a year it is checked with measuring equipment whether the amount for each atomizer is the same.

Add air and check the atomization. Test whether the fan provides the necessary air pressure. This is checked by giving maximum and minimum air pressure (from 25 to 4 mbar) Make sure that there are no impurities, paper or leaves in the atomizers and boom tubes.

Check for leaks in boom pipes, especially at boom joints.

#### Procedure before spraying

1. Suction- and pressure filter
2. Sufficient agitation in the tank
3. Fluid hoses
4. Anti-drip
5. liquid flow from the atomizers
6. Air pressure
7. Leaks from the boom

#### 10.2.4 Calibration of flow gauge (liquid gauge)

Before using the sprayer, the flow meter must be adjusted to ensure that it counts the correct number of liters of spray liquid. Calibration is usually performed only once a year before a new spraying season. Calibration is performed with clean water while the tractor is stationary. During calibration, the sprayer must be stationary and secure (on legs or solid ground) to ensure accurate readings on the tank.



**Relating to. procedure for calibration, refer to the sprayer computer manual on setting up the monitor.**

#### 10.2.5 Test run in the field

To ensure that everything on the sprayer works properly, it is recommended to perform a test run in the field with clean water. During this test run, all the functions and setting options of the sprayer are tested.

#### 10.2.6 Choice of working width

It is possible to choose between full working width or 12, 14 and 24 meters working width (depending on the model). When spraying with a working width of 12 and 14 meters, the outer joints of the boom do not unfold. Blind flaps are fitted at the end of the inner boom tubes and the section valves for the outer boom sections are closed.



**With a 3-part boom, a working width of 12 m cannot be used, as the outer boom towers hits the air distributor.**

#### 10.2.7 Adjusting the sprayer boom

All booms on a danfoil sprayer are adjusted to the correct position from the factory. However, it may happen that the boom moves during the transport of the sprayer. Therefore, it can be necessary to make readjustments

before using the sprayer. In addition, the boom must be adjusted at least once a year to ensure that the boom is always in the correct position both when spraying in the field and in the transport position.

A continuous test can be made as to whether the spray boom is adjusted correctly. By unfolding the boom and visually checking whether all atomizers are on a straight line and that there is no tendency for the boom to sway. If this is the case, the wires that carry the boom must be adjusted so that all the atomizers are in the same straight working position.

Procedure for adjusting the boom in spray position:

1. The boom must be unfolded, make sure that the outer boom cylinder piston is moved all the way out.
2. Tighten the front outer piston stop bolt.
3. The locking nut is subsequently tightened.
4. The boom must be folded, make sure that the outer boom cylinder piston is fully retracted.
5. Tighten the rear outer piston stop bolt.
6. The locking nut is subsequently tightened.

### 10.2.8 Adjusting the boom to transport position

It is important that the boom is always in a correct transport position, otherwise the boom may be damaged. To adjust the boom to the transport position, use the adjustable wire holder and the adjustable pivot point mounted on top of the boom tower.

#### Procedure for adjusting the boom in the transport position:

Fold the boom in slowly, making sure that the outer boom fits correctly into the boom holder bracket.

If the boom is too high, the wire tensioner on the boom tower must be adjusted backwards.

If the boom is too low, the wire tensioner on the boom tower must be adjusted forward.

The inner boom must be correctly positioned in the boom holder on the sprayer, be aware that the boom holder can be adjusted so that the transport height is changed.



**WRONG: The boom must rest on boom holders.**





**Boom holder for inner boom must be adjusted.**



**The machine must stand on level ground when unfolding or folding.**



**The boom must only be serviced in the unfolded position at a height of 1.2 meters.**



**Service of the boom at a height of more than 1.2 meters, must only be performed with the boom in the transport position.**

## 11 Lubrication and maintenance scheme:

COMPONENT	ACTION	DAILY	WEEKLY	ANNUAL
<b>PUMP</b>	Inspect oil level	X		
	Oil replacement			X
	Control of pressure accumulator 1.5 bar			X
<b>HYDRAULIC HOSES</b>	Inspect hydraulic hoses		X	
	Replace			6 years
	Replacement due to wear			X
<b>AIR PRESSURE</b>	Check air pressure (approx. 1 Bar)			
<b>PRESSURE FILTER</b>	Clean	X		
		When changing chemicals		
	Replace			X
<b>SUCTION FILTER</b>	Clean		X	
	Replace			X
<b>HYDRAULIC FILTER</b>	Replace			2 years
<b>BOOMS</b>	Inspect spray pattern	X		
	Inspect wires in unfolded position		X	
	Inspect wires in transport position		X	
<b>LUBRICATION</b>	Swivel joints, intermediate joints and cylinders		X	
	Pendulum suspension, mech. Shock absorbers	X	X	
<b>WHEELS</b>	Retighten wheel nuts		X	

## 11.1 Lubrication

### 11.1.1 In the front

<p><b>Function:</b> Trackcontrol tow bar</p>	
<p><b>Description:</b> Four lubrication points for the tow bar at the front of the sprayer.</p>	
<p><b>Regularity:</b> Once a week</p>	

<p><b>Function:</b> Steerable tow</p>	
<p><b>Description:</b> Two lubrication points on each of the two cylinders located at the front of the sprayer.</p>	
<p><b>Regularity:</b> Once a week</p>	

### 11.1.2 In the rear

<p><b>Function:</b> Wheel axle</p>	
<p><b>Description:</b> Two lubrication points on each side of the wheel axle at the rear of the sprayer.</p>	
<p><b>Regularity:</b> Once a week</p>	

<p><b>Function:</b> Mech. Shock absorbers</p>	
<p><b>Description:</b> Two lubrication points on the shock absorber at each end. As well as a center for lubricating the discs inside the shock absorber.</p>	
<p><b>Regularity:</b> Daily</p>	

<p><b>Function:</b> Pendulum arm</p>	
<p><b>Description:</b> Two lubrication points on the pendulum arm which are located behind the air distributor.</p>	
<p><b>Regularity:</b> Daily</p>	

<p><b>Function:</b> Pendulum joint</p>	
<p><b>Description:</b> One lubrication point located over the air distributor.</p>	
<p><b>Regularity:</b> Daily</p>	

<p><b>Function:</b> Individual boom lift</p>	
<p><b>Description:</b> Lubrication point at each cylinder for individual boom lift</p>	
<p><b>Regularity:</b> Once a week</p>	

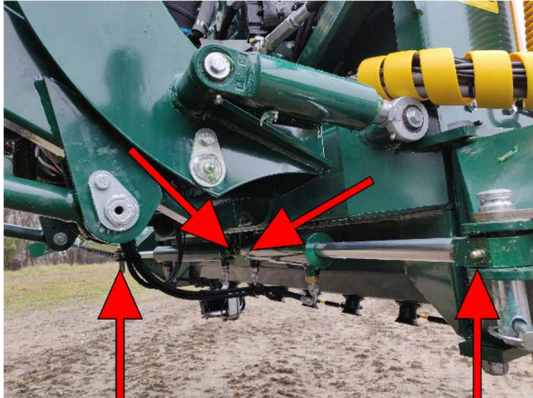
<p><b>Function:</b> Inner boom cylinder</p>	
<p><b>Description:</b> Two lubrication points on each of the two cylinders at the rear of the sprayer which unfolds the inner boom.</p>	
<p><b>Regularity:</b> Once a week</p>	

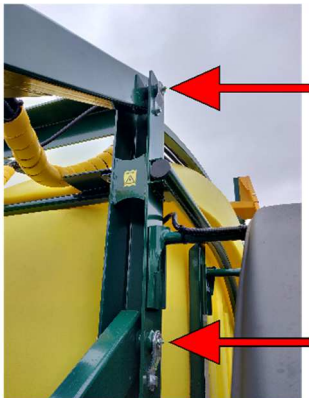
<p><b>Function:</b> Parallel arm</p>	
<p><b>Description:</b> Two lubrication points on the connection joints of the parallel arm to the main frame.</p>	
<p><b>Regularity:</b> Once a week</p>	



<p><b>Function:</b> Parallel arm</p>	
<p><b>Description:</b> Two lubrication points on the connection joints of the parallel arm to the rear console.</p>	
<p><b>Regularity:</b> Once a week</p>	

### 11.1.3 On the boom

<p><b>Function:</b> Wire tensioner</p>	
<p><b>Description:</b> Wire tensioner must be lubricated with grease where it connects with the wire.</p>	
<p><b>Regularity:</b> Once a week</p>	

<p><b>Function:</b> Swivel joint</p>	
<p><b>Description:</b> Swivel joint for folding of outer boom</p>	
<p><b>Regularity:</b> Once a week</p>	

## 12 Dosage and filling of plant protection products

### 12.1 Dosage recommendations

The chapter lists the recommended amounts of water and dosages for pesticides that are recommended for the danfoil sprayer.

**Please note**, that the dosing instructions for the individual pesticides refer to the dosage that would have been used for the same task at the same time in a traditional sprayer.

**Also note**, that all the mentioned spraying instructions are for guidance only. As a number of conditions at the time of spraying may mean that the instructions and spraying technique must be changed.



**Always read the pesticide supplier's instructions regarding the use of the individual agents, mixing options and order, protective measures, cleaning the sprayer, etc.**

If there is any doubt about mixing possibilities and concentration, make a proportional mixing in a bucket.

2018-09-05-18/JSM

Crop / treatment		Crop stage [BBCH]	Air-pres- sure [mbar]	Dosage *) com- pared to conven- tional sprayers [%]	Liquid con- sumption [l/ha]	Speed [km/h]	Recommended boom height [cm]
Grain	Fungicide	12 – 30	12 – 16	80	35 – 45	6 – 10	50
		31 – 47	16 – 22	80			
	Insecticide	31 – 47	16 – 22	80			
	Growth regulation	20 – 47	15 – 22	75			
	Wild oats	30 – 32	12 – 18	80			
Soil herbicide	0 – 10	8 – 14	100	50			
Rapeseed	Fungicide	12 – 30	12 – 18	100	35 – 45	6 – 10	50
		31 – 47	15 – 22	100			
	Insecticide	10 – 30	12 – 16	80			
	Insecticide	20 – 47	14 – 20	80			
	Growth regulation	20 – 47	15 – 22	90			
	Deportation		18 – 25	80			
Herbicide	10 – 30	10 – 18	100	40 – 50			
Peas	Fungicide	12 – 30	12 – 18	90	35 – 45	6 – 10	50
		31 – 47	15 – 22	90			
	Insecticide	31 – 47	10 – 16	80			
	Herbicide	10 – 30	10 – 16	80	40 – 50		
Seed grass	Fungicide	12 – 30	12 – 18	90	35 – 45	6 – 10	50
		31 – 47	15 – 22	90			
	Insecticide	31 – 47	15 – 22	80			
	Growth regulation	12 – 30	12 – 16	75			
	Growth regulation	20 – 47	15 – 22	75			
Herbicide	10 – 30	10 – 14	90	40 – 50			
Sugar beets	Fungicide	12 – 47	12 – 18	90	35 – 45	6 – 10	50

	Insecticide	10 – 47	15 – 22	80			
	Herbicide	10 – 30	10 – 14	80	40 – 50		
<b>Potatos</b>	Fungicide	12 – 30	12 – 16	100	35 – 45	6 – 10	50
		31 – 47	14 – 20	100			
	Deportation		15 – 20	65			
	Insecticide	31 – 47	15 – 22	80			
	Herbicide	10 – 15	10 – 14	90	40 – 50		
<b>Corn</b>	Fungicide	12 – 30	12 – 16	90	35 – 45	6 – 10	50
		31 – 47	15 – 22	90			
	Herbicide	9 – 13	10 – 14	100			
	Insecticide	31 – 47	15 – 22	80			
<b>In general</b>	Soil pesticides	0 – 10	8 – 12	100	50	6 – 10	50
	Manganese fertilizer	12 – 30	10 – 14	100	35 – 45		
		31 – 47	12 – 20	100			
	Quick grass before harvest, in good growth	47 – 75	18 – 25	70	30 – 35		
	Quick grass, after harvest	-	12 – 18	70			
<b>75% operational reduction</b>	all	5		50	Max. 6	40	
<b>90% operational reduction</b>	all	4		50	Max. 6	40	

\*) Guidance as a start-up dosage when a user switches from a standard sprayer to a danfoil sprayer.

After gaining experience with a danfoil sprayer, the user will typically reduce the dosage further.

## 12.2 Filling of plant protection products

First read the label on the pesticide packaging. The pesticides are filled into the tank through the chemical filler.

The chemical filler is activated by pressing the yellow button located on the left of the filler

1. Press the button and it will start flashing. Plant protection can now be added.
2. After the plant protection has been added, a thorough cleaning of the filler is carried out.
3. Press the button again to activate the cleaning program, which thus sends clean water into the filler.
4. After 18 sec. the button flashes faster, immediately close the valve at the bottom of the filler.

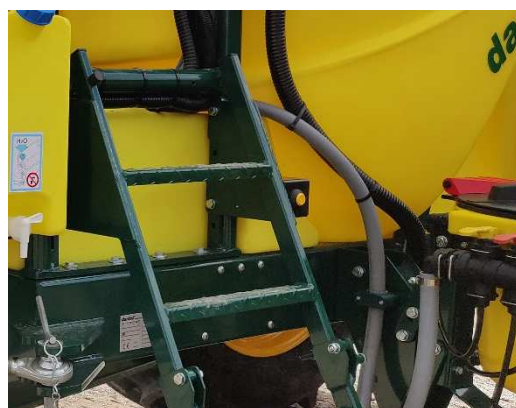

### 12.3 Precautions

During the spraying work, during cleaning and especially when preparing the spray liquid, the operator must show the utmost care. The various protective measures, the use of personal protective equipment and rules for the disposal of chemical residues and empty packaging are discussed in detail in instructions and pamphlets from e.g. The Danish Working Environment Authority, the Industry Safety Council for Agriculture and the Industry Committee for Agricultural Labor Market Training. **Read them!**



**The following protection equipment should be used:**

- Gloves
- Boots
- Headwear
- Respiratory protection
- Safety goggles
- Clothing that prevent chemical contact with skin



**You may not eat, drink, or smoke while working with plant protection products. Always have fresh water nearby. The content of the clean water tank can be drained from the tap at the bottom left of the footboard**



## 13 Spraying in the field

### 13.1 In general

During spraying, the main task of the operator is to provide the proper air pressure and the proper boom height. See the following regarding spraying technique.



**Remember that spraying in the field must not be started until the new spray liquid has displaced the rinsing water, which has been in the boom hoses etc.**



**Always consider wind conditions. Adjust the sprayer according to wind conditions in order to prevent shelterbelts and neighboring crops from being damaged or destroyed. Make sure that no persons or animals are in the range of spray mist.**

Do not perform any spraying tasks in case of strong wind. An anemometer can help to decide whether or not to spray.



**Spraying must be stopped when the monitor shows a decrease in performance (l/ha). When this occurs with the sprayer in the horizontal position, the residual amount in the sprayer is low. The residual amount should be kept to a minimum by avoiding driving on slopes when the tank is about to be empty.**

The deposition and penetration of the spray liquid on the crops can be examined and evaluated by placing small pieces of water susceptible paper on the plants.

### 13.2 Setting of air pressure

#### 13.2.1 General notes for air pressure

In the following, general directions for setting air pressure and boom height is described.

#### 13.2.2 On bare soil and low crops (stage 1-5):

Always spray with low air pressure (4-10 mbar) in order to obtain larger droplets and to lower the risk of drift. The height of the boom is to be adjusted in a way that the spray liquid is slightly touching the ground (the crops or small parts of plants on the ground must be gently moved by the air). When there is a risk of drift the operator must be very attentive to air pressure and height of boom.

#### 13.2.3 Beets

Sprayed under the guidance above (bare soil and low crops)

#### 13.2.4 Grain

When combating weed and during the first spraying task with fungicides (stage 1-5) spraying should be carried out with such a low air pressure that the plants are slightly moved by the air. Avoid too high air pressure since this can press down the crops. When crops grow the air pressure must be increased to ensure better deposition (stage 6-10). Higher air pressure leads to smaller droplets and therefore guarantees a better deposition onto the plants. The final spraying task (stage 10-11) must be carried out with an air pressure of approx. 22 cm mbar.





**When the boom height is too low (less than 40cm), the spray liquid is distributed unevenly (in lines)**

**13.3.2 Driving in head- and tailwind**

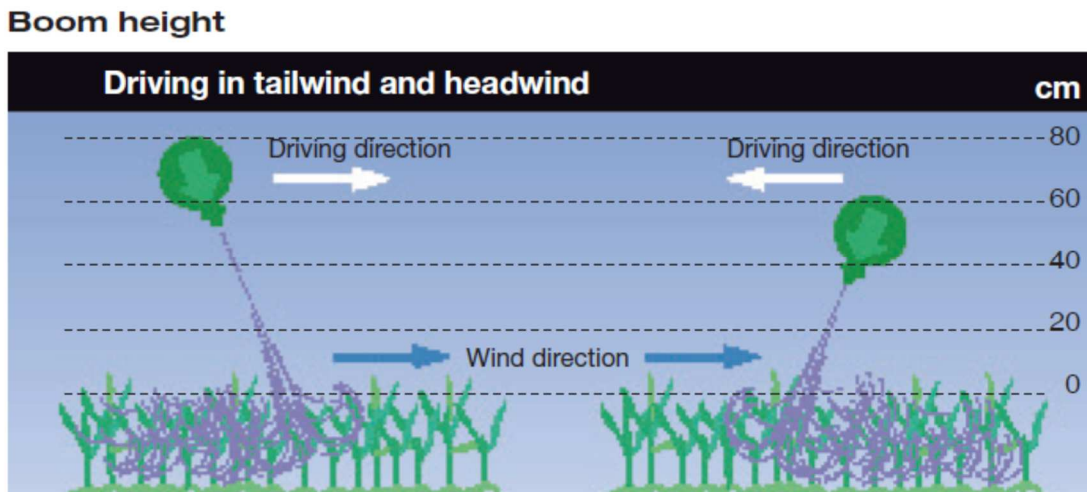

When using the Danfoil sprayer during windy weather conditions the driver must ensure that the atomizers' airflow is reduced in case of headwind. Therefore, the boom's height must be lower than its height when driving in downwind.

If the wind is coming diagonally from the front then the boom on the wind-facing side must be lower than the boom in the lee of the tractor.

<b>Driving in tailwind and headwind</b>		
	Tailwind	Headwind
Boom height	High boom	Low boom
Driving speed	High speed	Low speed

**13.4 Recommended driving speed**

Recommended driving speed is 6-7 km/h. An even lower driving speed is recommended when spraying densely standing crops as well as beets.

## 14 Cleaning the sprayer

### 14.1 Cleaning instructions



The sprayer must be kept clean constantly – do not clean it only occasionally

For this, never let residues from spraying or chemicals remain in the sprayer and dry up. **Always pay close attention to the cleaning instructions written on the packaging of the plant protection product.**

### 14.2 Advices for cleaning

Keeping the sprayer clean is facilitated when flushing the sprayer properly with clean water immediately after every spraying task. Additionally, empty and rinse filters after every cleaning procedure.



Emptying, cleaning, and rinsing the sprayer should possibly be carried out on the field or on designated washing areas where the water can be collected.

Legal regulations regarding environmental protection must absolutely be obeyed.

#### 14.2.1 Eurofoil atomizers

The atomizers are cleaned most effectively when the air supply is completely opened and the cleaning liquid is pumped through the boom system. If the effect is not satisfying clean the atomizer with a brush and water as well as cleaning agent. **Never use a high pressure cleaner directly on atomizers**

#### 14.2.2 Warm water

Warm water increases the positive effect of the cleaning agent and accelerates the cleaning process. Especially after spraying **potatoes or similar plants** the sprayer must be properly cleaned, since hardly soluble chemicals are used. Finally, **remember to also clean both the tractor's and the sprayer's exterior surface.**

#### 14.2.3 Rinsing

After rinsing and cleaning the sprayer, do not start driving and re-spraying in the field until the rinsing water is completely out of the boom system and replaced by the new spray liquid.

## 14.3 Cleaning the sprayer

### 14.3.1 Beginning of spraying season

At the beginning of the season clean the sprayer with warm water and an officially approved cleaning agent. Repeat this procedure several times. Check if the liquid supply in the boom is correct and well-functioning. The following checklist can be used to ensure that the sprayer is ready for the spraying season:

1. Liquid pump:
  - a. Oil change
  - b. Be aware that the oil is clean. If the oil is gray or whitish in color the diaphragm in the liquid pump must be changed
  - c. The one-way valves should be replaced every 2 years
  - d. Inspect parts for wear and tear and possibly replace
2. Water system
  - a. Clean and inspect filters
  - b. Inspect flow meter
  - c. Retighten electrical motor valves
3. Hydraulics
  - a. Inspect hydraulic lines
  - b. Change oil filter
4. Boom and air distributor
  - a. Check air pressure
  - b. Check atomizers (both fluid and fluid+air)
  - c. Check boom sections for foreign objects
  - d. Adjustment of the boom
  - e. Lubrication of swivel joints, cylinders and shock-absorbers
  - f. Cleaning or replacing of diaphragm in anti-drip
5. Sprayer
  - a. It is recommended to lubricate the sprayer with thin oil before starting spraying, as this may ease future cleaning

### 14.3.2 Emptying of residual amount

Emptying the residual amount from the sprayer is done via the valve under the tank. **NB: Be aware that after this emptying there is still spray liquid left in the pump, filters and hoses.**

This residual amount can be led to the tank by letting the pump suck clean water in from the clean water tank.

### 14.3.3 Procedure for cleaning the tank

The following procedure is recommended for cleaning the tank:

1. When the tank is almost empty, select the automatic washing program through the DSC-screen.
2. The sprayer then starts the automatic washing program

3. When liquid comes out of the atomizers, drive then forward so that it is distributed on the field.

Most often one tank cleaning program is sufficient, but it is of course up to the situation to assess whether an additional tank cleaning run should be performed.

#### 14.3.4 Rinsing boom system and flow gauge (Quick Clean)

Flushing of the boom system and flow meter is done in the field with water from the clean water tank through the washing program Quick Clean. It can be activated directly through the DSC-screen. This washing program must be used for shorter stops to avoid clogging of the boom system.

#### 14.3.5 Daily cleaning

Daily cleaning after spraying with *easily soluble preparations*, which do not form coatings, can usually be carried out with sufficient effect when emptying the tank, and then using the washing program. The filters are then emptied and cleaned.

After spraying with *sparingly soluble preparations* which may form coatings, the entire spray system must be thoroughly cleaned with water with an effective cleaning agent. Add the detergent to the clean water tank and use the tank cleaning program. The atomizers are cleaned with a brush and water with detergent. The filters are emptied and cleaned, and the clean water tank is completely emptied. Then refill the clean water tank with clean water and run the tank cleaning program again so that the entire sprayer is rinsed thoroughly with clean water.

#### 14.3.6 Cleaning when changing plant protection product

Cleaning in between chemical changes must be done very carefully. Also remember to clean the chemical filler. The chemical packaging often contains good cleaning instructions. **Also see chapter 15 Cleaning Procedures.**

#### 14.3.7 Exterior cleaning

The external cleaning of the tractor and sprayer is carried out as required with a recognized cleaning agent and high-pressure cleaner. **Remember do not use a high-pressure cleaner on the atomizers.**

#### 14.3.8 End of spraying season

Cleaning of the sprayer at the end of the season is to be completely carried out as described above, both internally as well as externally as described above. Additionally, the anti-drip valve has to be cleaned as follows: Demount the **anti-drip** valves and place them in a bucket with cleaning agent. After several hours take the anti-drip valves out, rinse them off and blow them with high air pressure before remounting. It is recommendable to check and exchange the **section valves** if necessary. If the sprayer is used very often it is recommendable to change the **membranes** in the pump once a year.

#### 14.3.9 Antifreeze protection

Frost protect the sprayer before the winter by filling antifreeze in the clean water tank and pump it with water through the sprayer and the boom (e.g. 40 liters of water + 15 liters of antifreeze). **Please remember to empty the filter from antifreeze**

1. We recommend using anti-freeze for frost protection (Ethyleneglycol)
2. Empty the sprayer as good as possible for residual liquid
3. Clean the interior and exterior of the sprayer thoroughly
4. Activate the chemical filler and fill 20 l. Of water and fill 5 l. Of coolant. This mixture secures the sprayer to -13 degrees
5. Now frost secure the chemical filler. Remember to activate all the handles.
6. Start the tank wash program
7. Close the section valves when you can see the blue coolant in the outer atomizers.
8. The residual amount is drained from the tank, as well as the suction and pressure filter



9. The residual amount can subsequently be used for frost protection of the clean water tank and clean water pump through the washing program Quick Clean.
10. Possibly, emptying high pressure cleaner for water.
11. If there is additional coolant mix left, it is saved and used next year
12. Remember to keep out of the reach of children
13. Remember to empty filters

#### **14.3.10 Other winter preparation tips**

- Store your danfoil control computer and joystick in a dry room to avoid humidity.
- Check if the computer box on the sprayer is intact in order to avoid condensation in the box, as this can damage the circuit board.
- Check that the electricity grid on the sprayer is intact, in order to avoid damage and short circuit at start-up.

## 15 Cleaning procedures

<p><b>DU PONT recommends the following:</b></p> <p><b>Cleaning of the sprayer after</b> <b>Ally 20 DF, Express &amp; Glean 20 DF.</b></p> <p><b>1.</b> Just after having finished the spraying task clean the sprayer thoroughly with clean water. Then, the water can also be sprayed on the crop. Remember also to clean the sprayer on the exterior surface.</p> <p>During the cleaning procedure all vents and taps should be activated to ensure that all hoses are cleaned. Additionally, the sprayer needs to be completely emptied between each flushing.</p> <p><b>2.</b> Fill up the sprayer with water mixed with 0,3 liters threefold ammonia solution per 100 liters water (see also other cleaning agents listed below*), rinse hoses and boom, refill the tank with water and leave it for at least 15 min. to be stirred by the rotary tank cleaner. Empty the sprayer through the boom/atomizers – flush tank and boom with clean water.</p> <p><b>3.</b> Atomizers and filters are cleaned separately with the same cleaning agent and concentration as used for the sprayer.</p> <p><b>4.</b> Repeat step 2.</p> <p><b>5.</b> Rinse tank/sprayer well for 5 min. Simultaneously, squirt out the rinsing water through boom/atomizers.</p> <p>Caution: Remember to only release water in areas where trees, crops, groundwater, river or other natural water resources could be negatively affected.</p> <p>* Other cleaning agent approved by <b>DU PONT</b></p> <table border="0"> <tr> <td>Ordinary ammonia solution</td> <td>1 liter / 100 liters water</td> </tr> <tr> <td>PLK-Red sprayer cleaner</td> <td>1 liter / 100 liters water</td> </tr> <tr> <td>KVK sprayer cleaner</td> <td>1 liter / 100 liters water</td> </tr> <tr> <td>Red sprayer cleaner (Shell)</td> <td>1 liter / 100 liters water</td> </tr> <tr> <td>Clarén <b>CitriKleen</b> Eco</td> <td>2-2½ liters / 100 liters water</td> </tr> <tr> <td><b>DU PONT</b> All Clear Extra</td> <td>½-1 liter / 100 liters water</td> </tr> </table>	Ordinary ammonia solution	1 liter / 100 liters water	PLK-Red sprayer cleaner	1 liter / 100 liters water	KVK sprayer cleaner	1 liter / 100 liters water	Red sprayer cleaner (Shell)	1 liter / 100 liters water	Clarén <b>CitriKleen</b> Eco	2-2½ liters / 100 liters water	<b>DU PONT</b> All Clear Extra	½-1 liter / 100 liters water	<p><b>danfoil a/s has experience with the following cleaning procedure:</b></p> <p><b>1.</b> Empty the sprayer, remember filters.</p> <p><b>2.</b> Flush with 30-60 liters clean water. Adjust to the highest amount of liquid possible to create an effect of high-speed rinsing. Empty the whole sprayer</p> <p><b>3. Cleaning</b> 40-60 liters water + 1-3 kg caustic soda or approved cleaning agent e.g. CitriKleen.</p> <ul style="list-style-type: none"> <li>- <i>The mixture is sent through hoses and boom</i></li> <li>- <i>Activate all valves and taps</i></li> <li>- <i>The mixture remains in the system for 10-15min</i></li> <li>- <i>The inside of the tank is rinsed</i></li> <li>- <i>The atomizers are cleaned (brushed)</i></li> <li>- <i>The outside of the tractor &amp; sprayer is cleaned</i></li> <li>- <i>Emptying through the boom (with air)</i></li> <li>- <i>Filters are emptied and cleaned.</i></li> </ul> <p><b>4. Rinsing</b></p> <ul style="list-style-type: none"> <li>- <i>The system should be rinsed 2 times entirely</i></li> <li>- <i>Optionally, mix Lissapol into the water of the last rinsing procedure.</i></li> </ul> <p><i>After spraying with Ally, Express and Glean the following disinfection has to finish the cleaning procedure:</i></p> <ul style="list-style-type: none"> <li>- <i>The tank is completely filled up with water and additionally mixed with 1,0 liter ammonia water (3%) or 0,3 liter threefold ammonia water (9%) per 100 liters water</i></li> <li>- <i>The mixture is sent through hoses and boom</i></li> <li>- <i>The tank is refilled with water</i></li> <li>- <i>The mixture remains in the system for 10-15min</i></li> <li>- <i>The exterior surface of the tractor and the sprayer is cleaned</i></li> <li>- <i>Emptying of sprayer - (some part through the boom with air)</i></li> </ul> <p><i>Rinsing and emptying of filters</i></p>
Ordinary ammonia solution	1 liter / 100 liters water												
PLK-Red sprayer cleaner	1 liter / 100 liters water												
KVK sprayer cleaner	1 liter / 100 liters water												
Red sprayer cleaner (Shell)	1 liter / 100 liters water												
Clarén <b>CitriKleen</b> Eco	2-2½ liters / 100 liters water												
<b>DU PONT</b> All Clear Extra	½-1 liter / 100 liters water												

### 15.1.1 Good advise for cleaning



**After every rinsing and cleaning procedure empty and clean the filters.**

**Insufficient cleaning** can cause partly or completely clogging of the sprayer. In this case, rinse immediately with warm water and add cleaning agent.

**Remember always to follow the instructions on the cleaning agent.** The mixture is run through the system out to the atomizers. Empty the rest of the tank and filter. Allow the cleaning agent to work for a few hours, preferable overnight. Then follow the procedure from the table above to rinse. Mix a soap product into the last rinse water in order to prevent the hoses and gaskets from drying



**Never leave spray or chemical residues sit in the sprayer and dry. Always read the instructions as listed on the individual plan protection products.**

## 16 Troubleshooting

PROBLEM	CAUSE	SOLUTION
Frequent blockaging of atomizers	Filter cartridges leak	Replacement
	Impurities inside the system	Thorough cleaning
An atomizer applies too small amount/nothing	The throttle in the side of the atomizer is blocked	Cleaning
Two neighbouring atomizers apply too small amount	The anti-drip device is stuck	Cleaning
	The throttle on the hose is blocked	
Bad atomization	Impurities in the atomizer	Remove impurities
	The trailing edge is not sharp	Replacement
Max. output is too low	Filter is blocked	Cleaning
	The pressure valve needs adjustment	Contact dealer
The indication of the flow gauge varies	Poor cleaning of the system	Thorough cleaning
	Error indication in speed: Fault at the wheel sensor / magnet (magnets) is/are missing	Check the wheel sensor/magnets
<b>Hydraulics</b>		
No hydraulic functions	Loss of power on sprayer	Check plug in printed circuit board
		Check power supply (fuses, relays and cables)
Cylinders are not working	Impurities in the oil	The restrictor on the block of valves is cleaned
<b>Air</b>		
Descending air pressure	Motor speed is too low	Accelerate the motor speed
	The boom leaks at the swivel	The boom is completely unfolded and the gaskets are replaced
<b>Electricity</b>		
Monitor will not start	Lack of power	1. Check 3 amp fuse

		2. Check signal cable
		3. Check plug in printed circuit board
<b>Spray liquid</b>		
No or to small amount of liquid too the boom	Filters are blocked	Cleaning
	Liquid hose is jammed/twisted	Free the liquid hose
	The section valves are not opening	Lack of power supply Check the fuses etc. Poor cleaning

## 17 Appendixes

### 17.1 Wiring diagram for installation kit

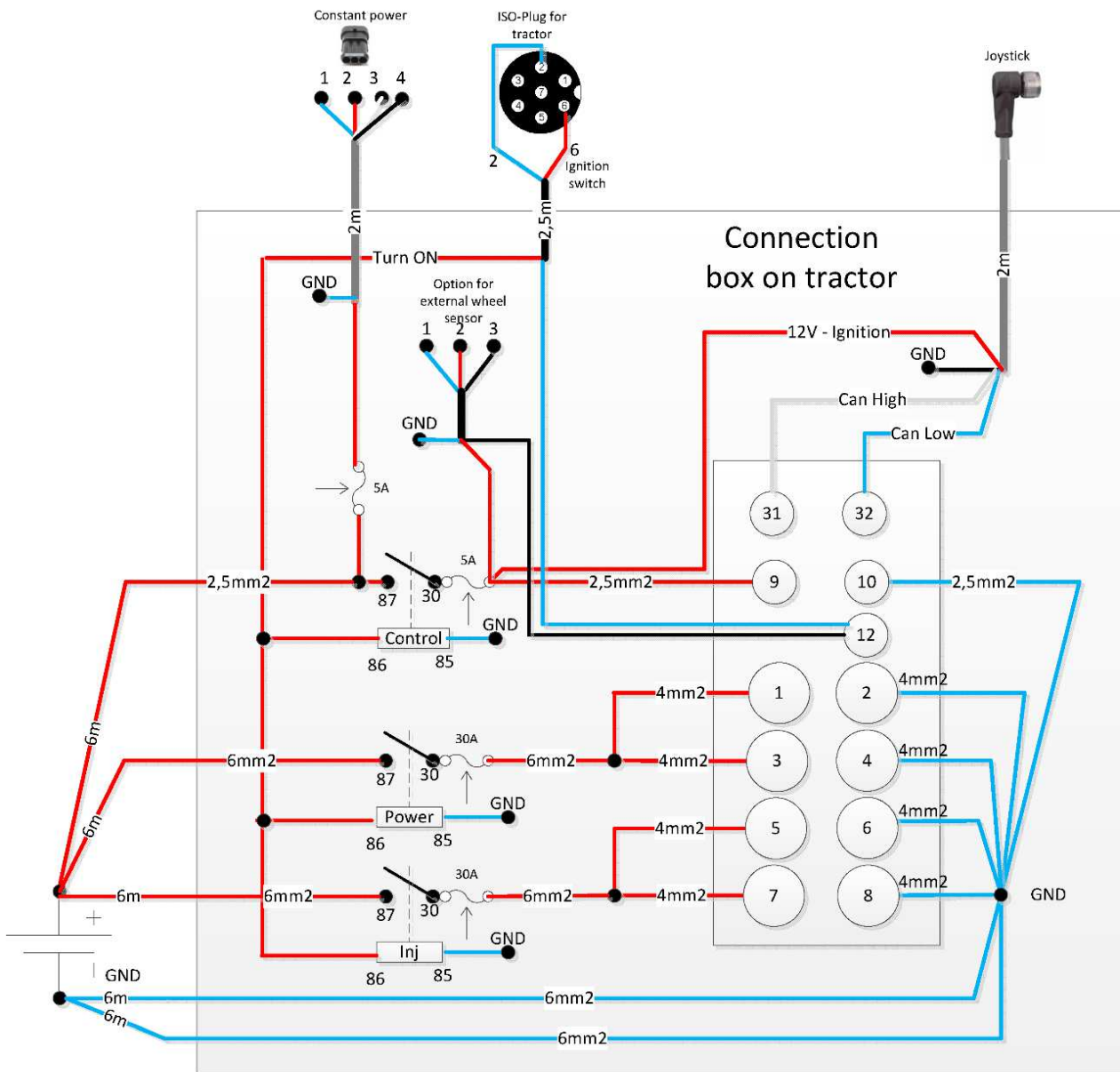



## 17.2 The sprayers liquid and valve system

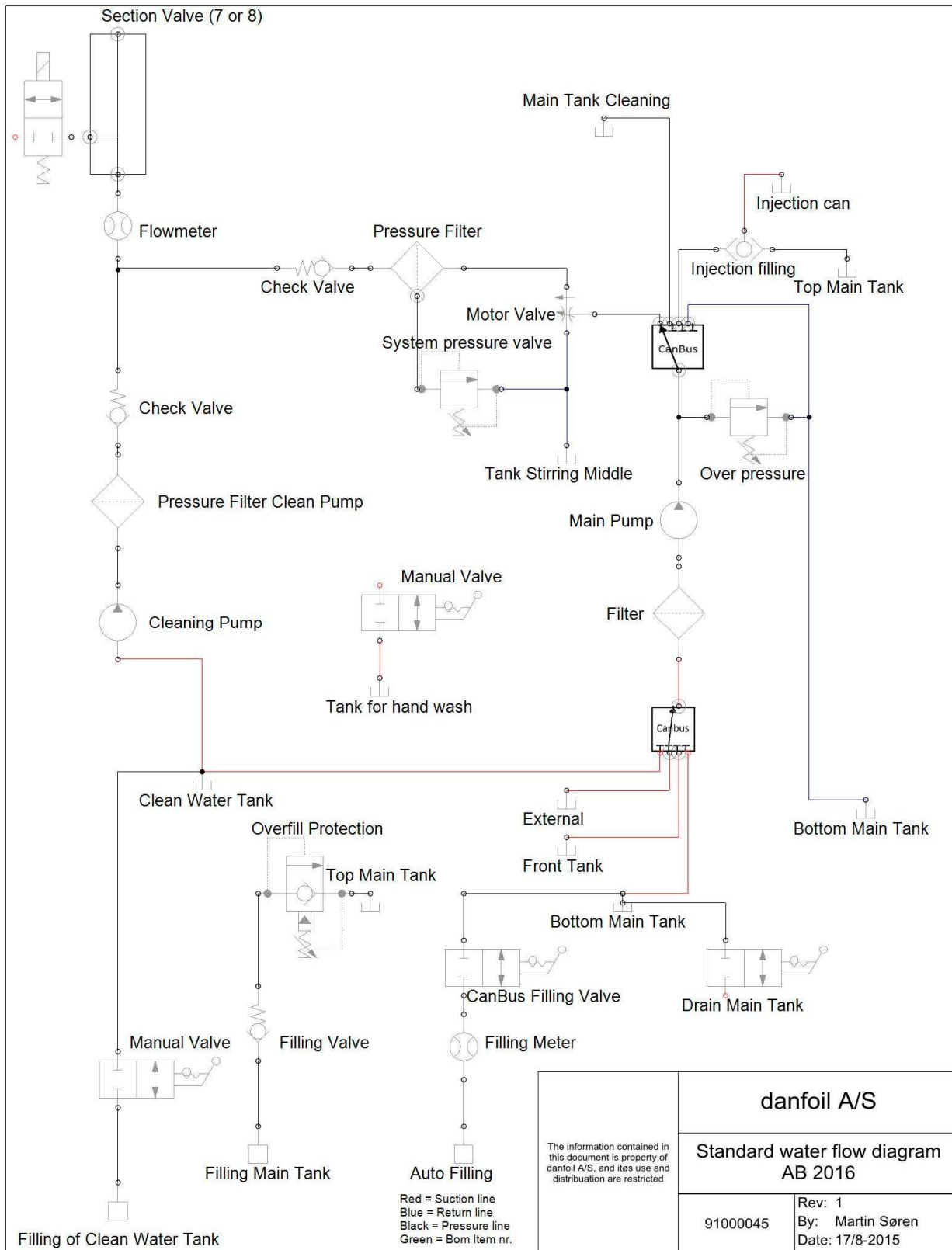









# FOLLOW US



**Danfoil**<sup>+</sup>  
®

Jellingvej 14 | DK-9230 Svenstrup J  
Tlf. +45 98 67 42 33  
www.danfoil.dk | info@danfoil.dk